

## SWEEPMASTER F SERIES

### HYDRAULIC FRONT SWEEPER

#### COMPATIBLE VEHICLES

- Tractor
- Special Equipment Truck
- Wheel Loader
- Unimog Truck
- Forklift

# SWEEPMASTER F SERIES

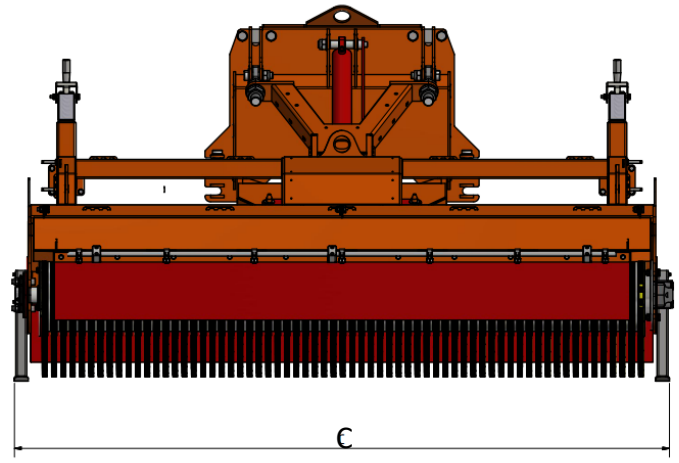
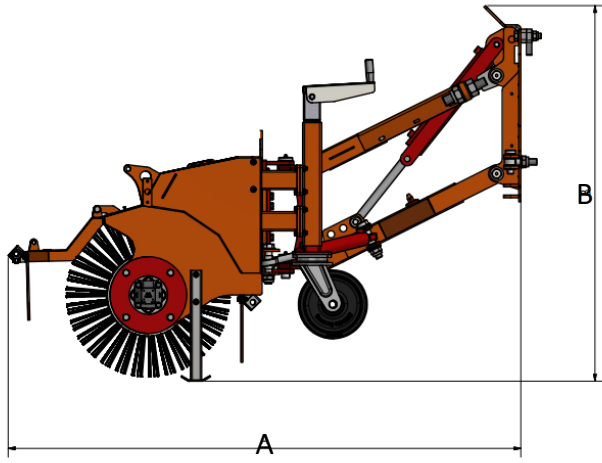

## TECHNICAL DATA

SWEEPMASTER	F 2000	F 2200	F 2400	F 2600	F 2800
HYDRAULIC PUMP	27cc				
DRIVE MOTOR	250cc/720Nm				
SYSTEM PRESSURE	210 bar				
WHEEL CAPACITY	PU/2x1350 kg				
APPROXIMATE WEIGHT	650 kg	700 kg	750 kg	820 kg	950 kg
BRUSH TYPE	600mm Steel/polypropylene				
BRUSH SPEED	Min/150 rpm Max/250 rpm				
NUMBER OF BRUSHES	50 piece	54 piece	60 piece	64 piece	70 piece
HUMIDIFICATION PUMP	24V /15 lt			24V /18 lt	24V /20 lt
RIGHT LEFT DIRECTION	Max.32°				
HORIZONTAL FLEX/TILT	+/- 5°				
A	1865 mm				
B	1370mm				
C	2000 mm	2200mm	2400mm	2600mm	2800mm

FOR INFORMATION PURPOSES, THE VALUES GIVEN MAY CHANGE